

472706 Rev00

Please read these instructions thoroughly before installation.

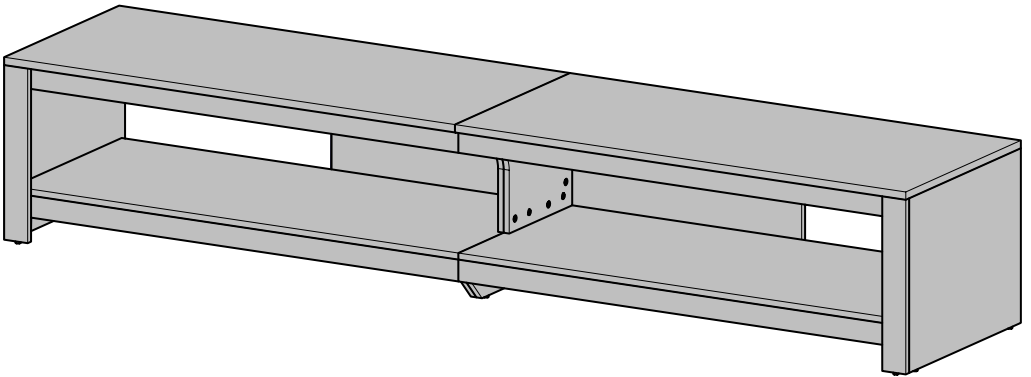

**108kg
238lb**

Helpline



0333 320 0463 (UK)

1300 762 219 (Australia)

(+64) 9 306 1020 (New Zealand)

UK - AVF Group Ltd. Hortonwood 30, Telford, Shropshire, TF1 7YE, England

Australia - Arisit P/L · 40-50 Mark Anthony Drive · Dandenong · South Victoria · 3175

IMPORTANT INFORMATION!

We advise that before starting the assembly of this product that you familiarise yourself with the instructions and the parts list in this leaflet.

Do not's

Do not overtighten any part of this assembly.

Do not place hot or cold objects on to or next to any wood surface unless the object is sufficiently insulated to prevent contact.

Do not strike the wood with hard or pointed items.

Do not sit, stand or climb upon any part of this furniture.

Do not use washing powders or other substances containing abrasives when cleaning the wood.

Do's

Do use a soft cloth with a suitable furniture polish when cleaning wooden panels.

Check all nuts and bolts from time to time.

Maximum TV weight and shelf capacities

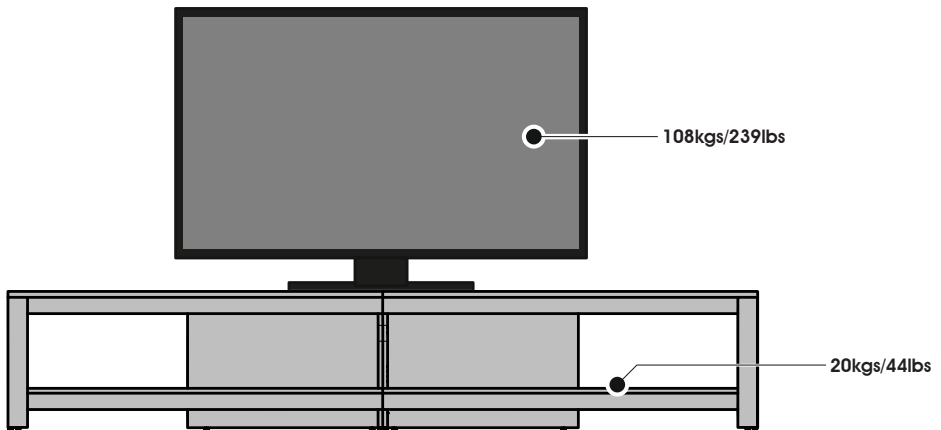

WARNING: Wherever possible distribute weight evenly.

 WARNING	
	
<p>Children have died from furniture tipover.</p> <ul style="list-style-type: none">• NEVER allow children to stand, climb or hang on drawers, doors, or shelves.• ALWAYS secure your television with an anchor device or mount the television on a wall. <p>Ask staff for more information or visit https://www.productsafety.gov.au</p>	

Boxed Parts

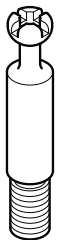
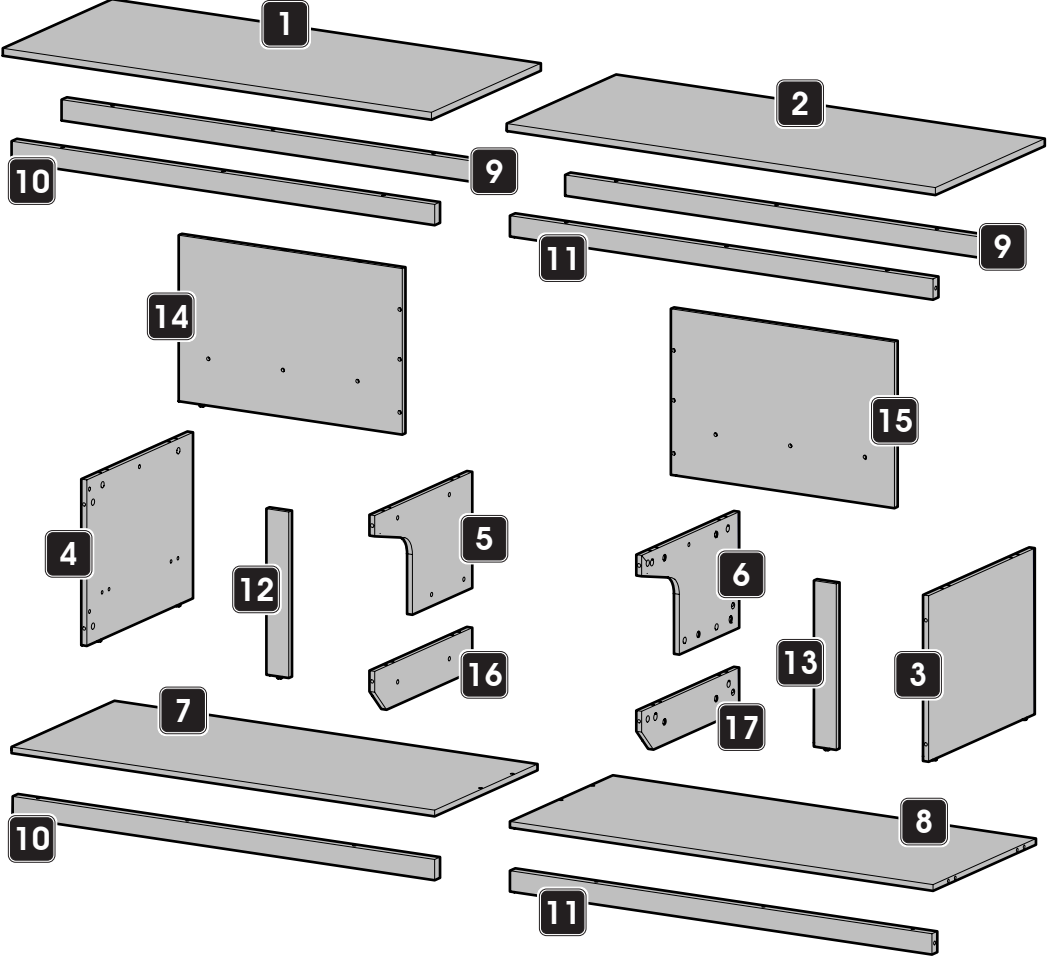

A
X72



B
X72



C
X16



D
X72

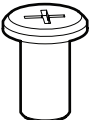

E
X6

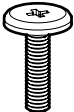

F
X6

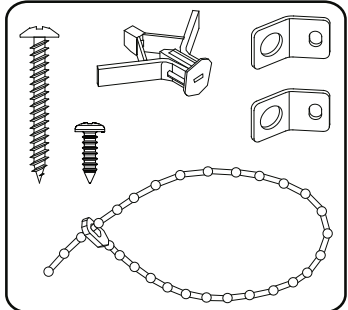

TR
X2



The stand is built in two halves. Start with the Left Hand half using the parts shown below.

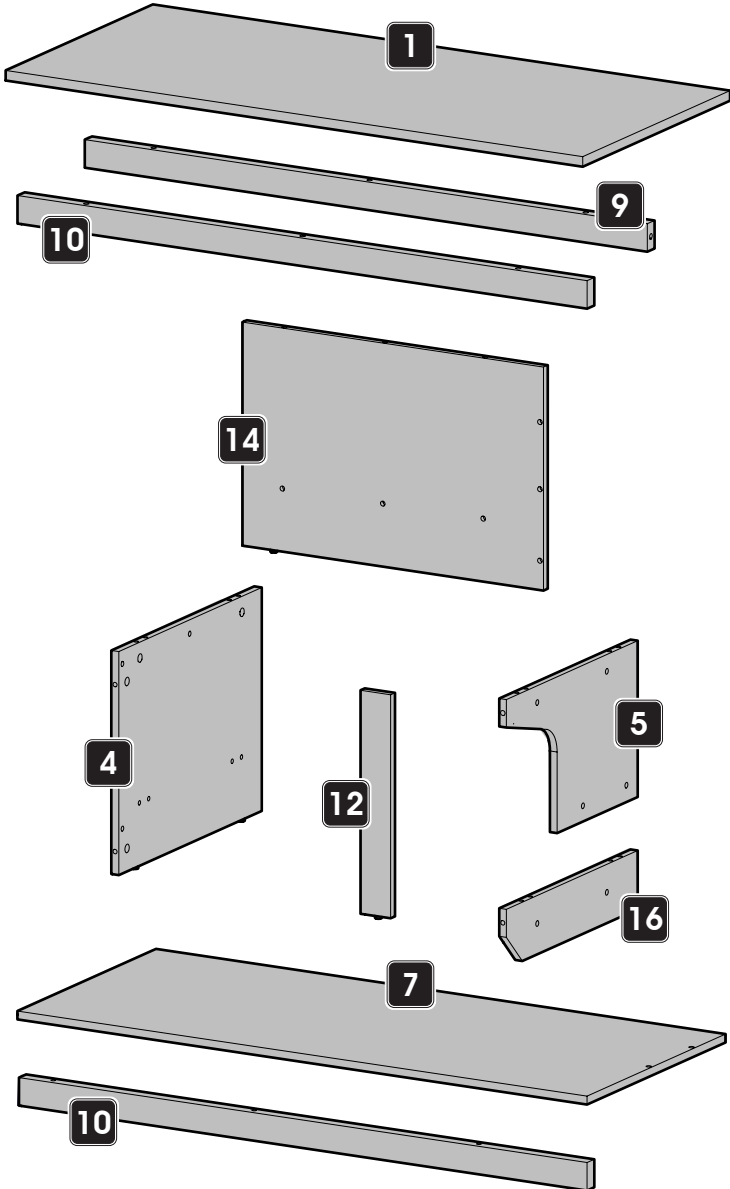

i

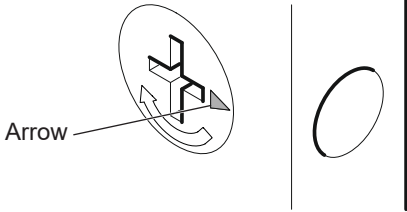

Always ensure that the arrow on part **B** points towards the edge of the panel.

i

DO NOT overtighten

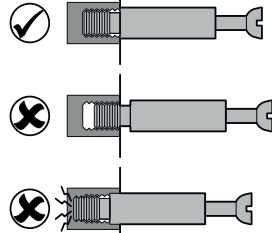

1

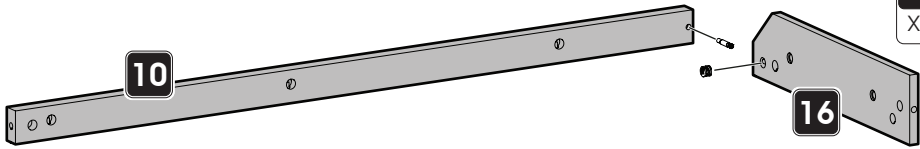
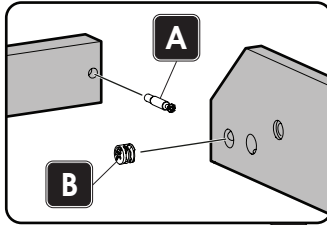

A
X1

B
X1

2

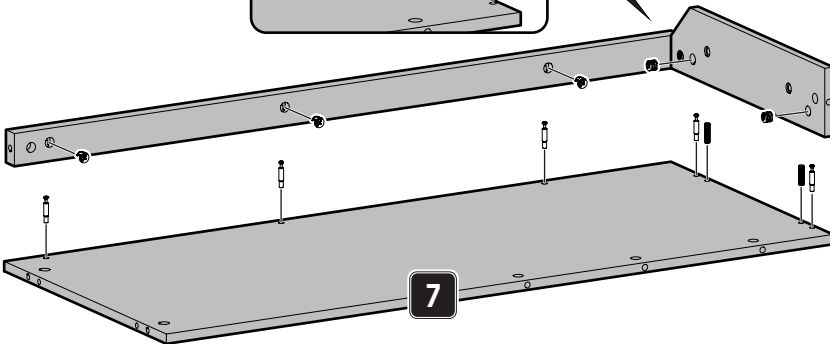
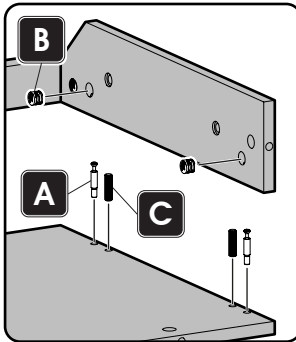

A
X5



C
X2

B
X5

3

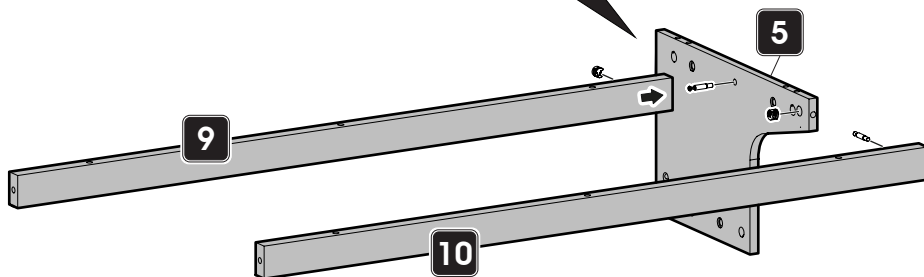
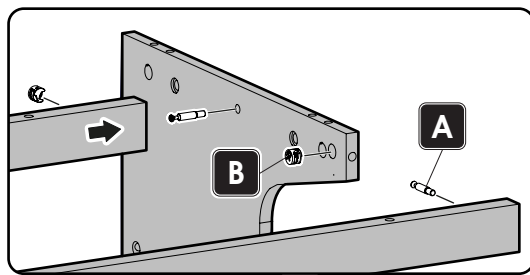

A
X2



B
X2

4

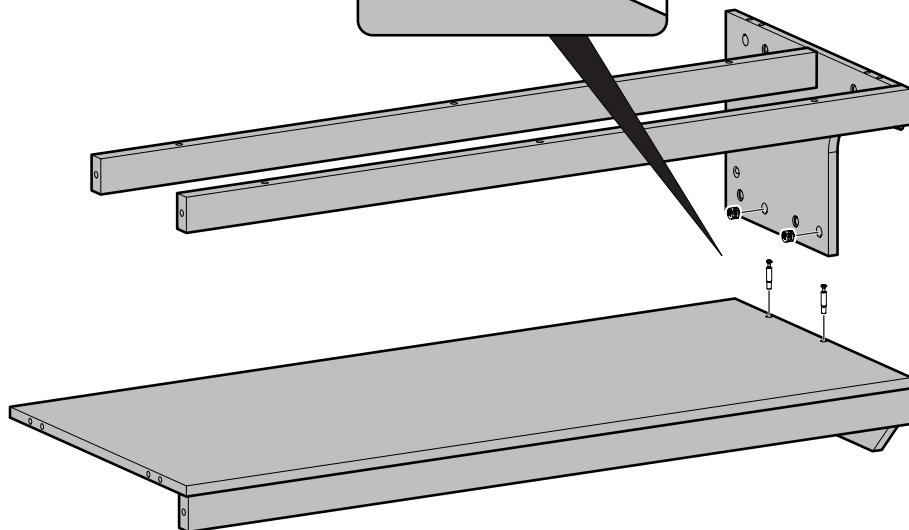
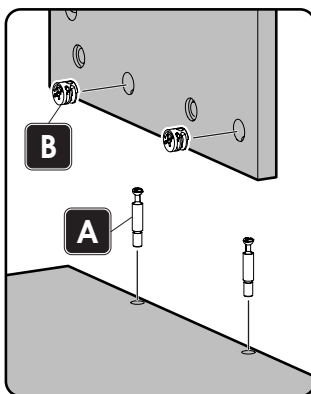

A
X2



B
X2

5

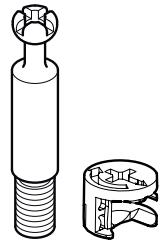
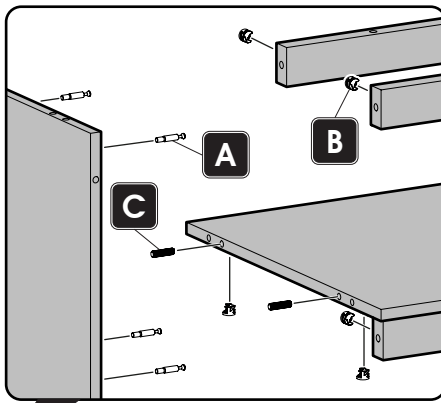

A
X5

B
X5

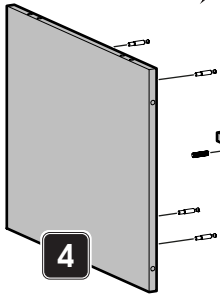

4

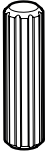
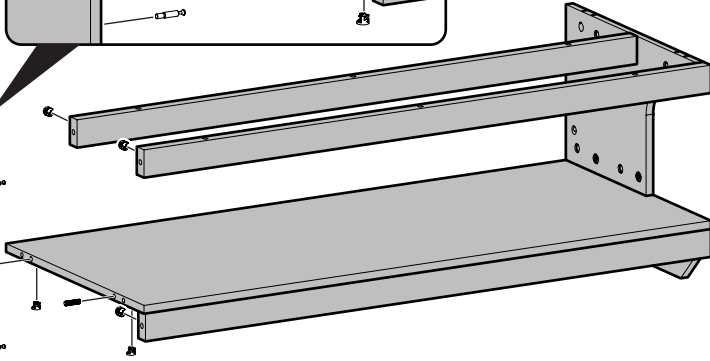

C
X2

6

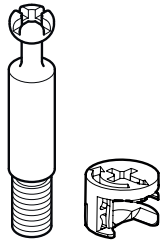
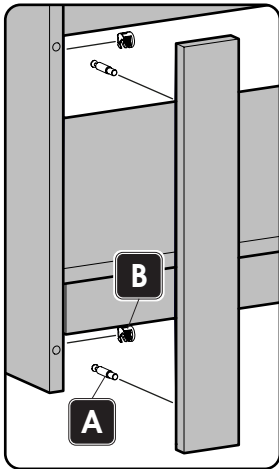

A
X2

B
X2

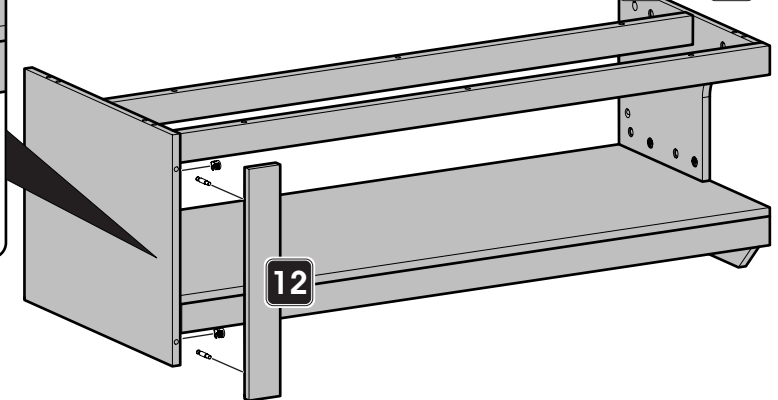

12

7

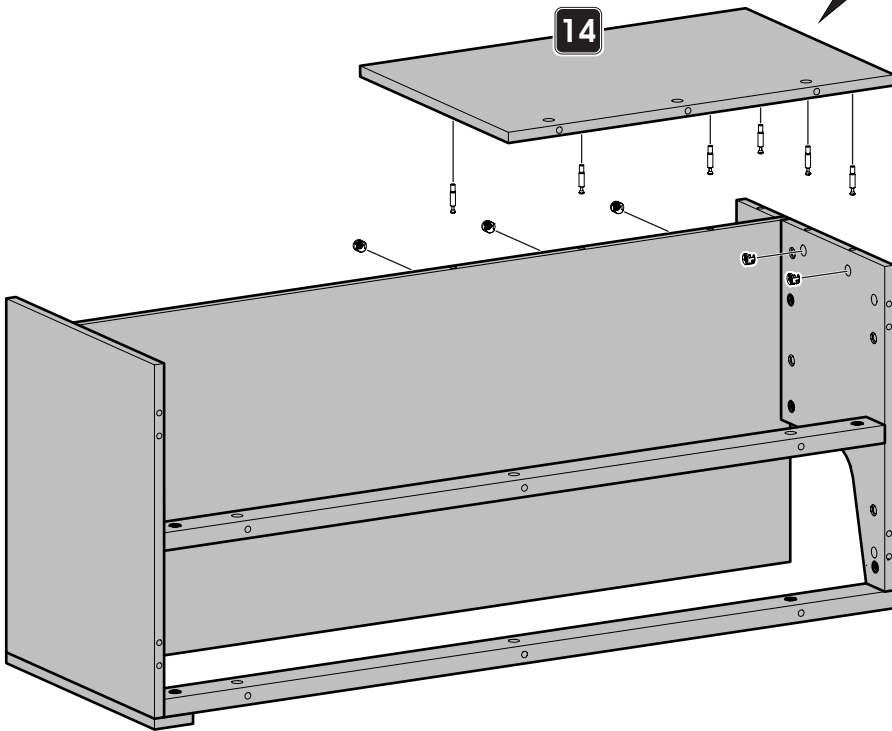
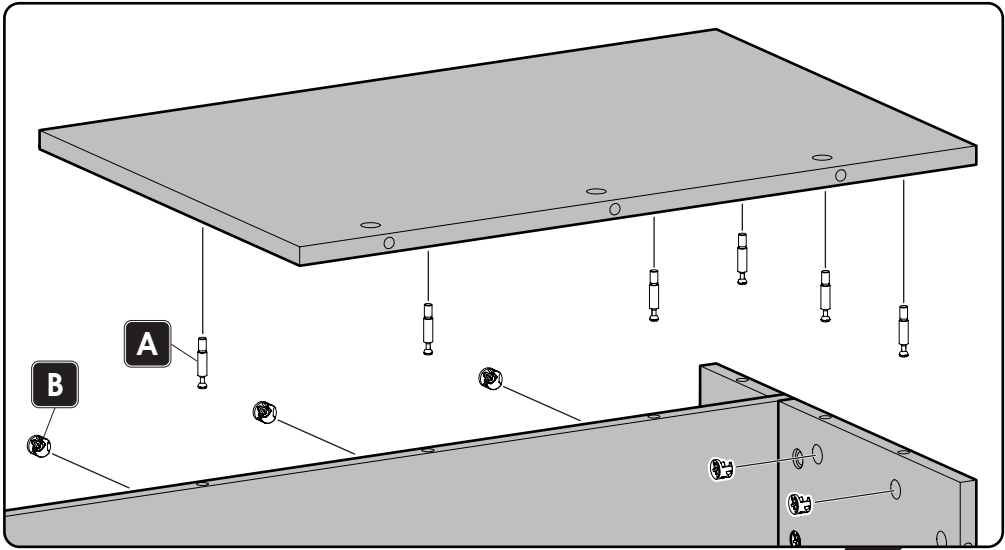
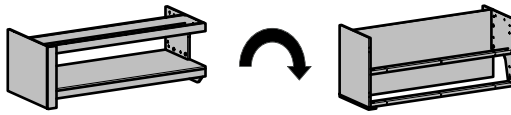

A
X6



B
X6

8

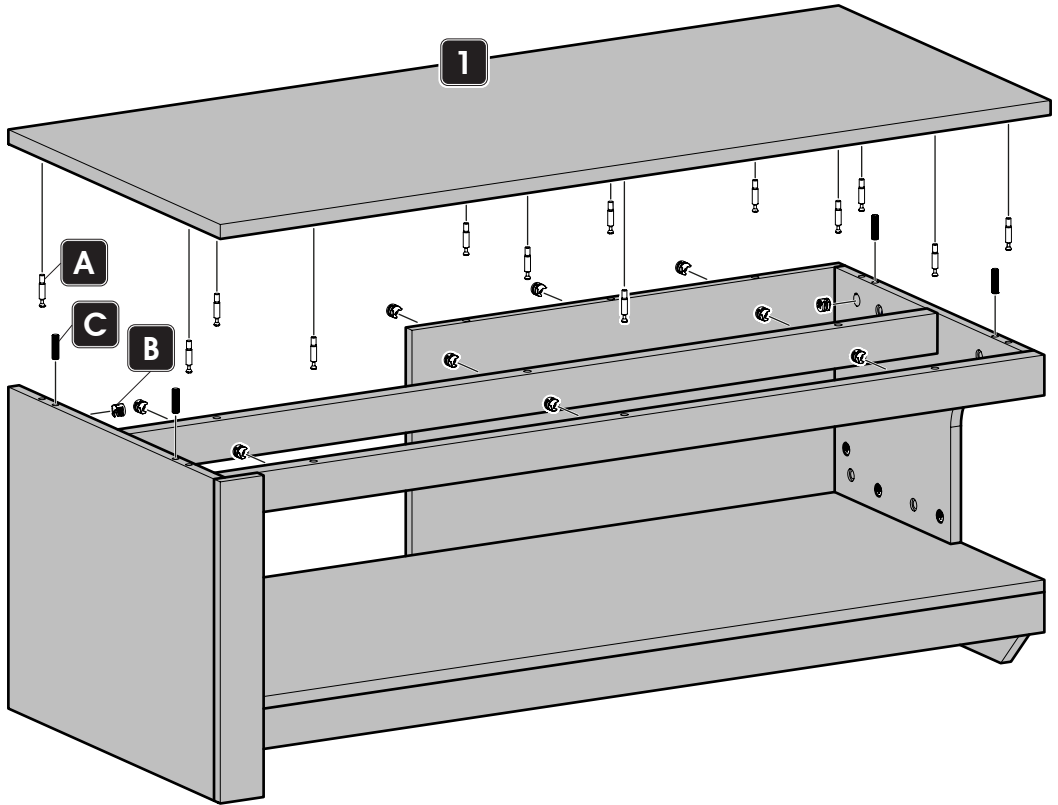
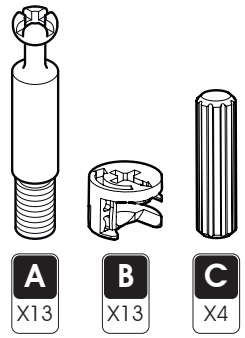

This completes the procedure to build the Left Hand half of the TV Stand.



The procedure to build the Right Hand half of the TV Stand is the mirror of the first 8 steps, using the parts as shown below.

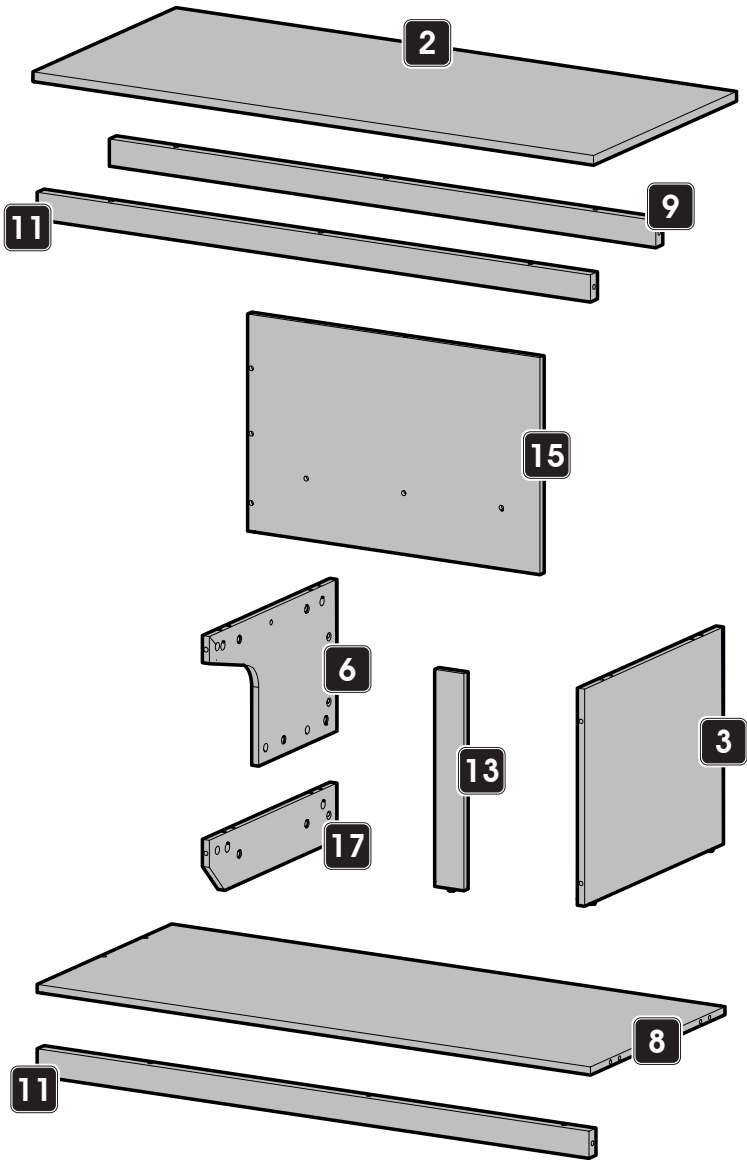

9

Joining the Two Halves of the TV Stand

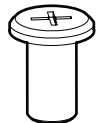
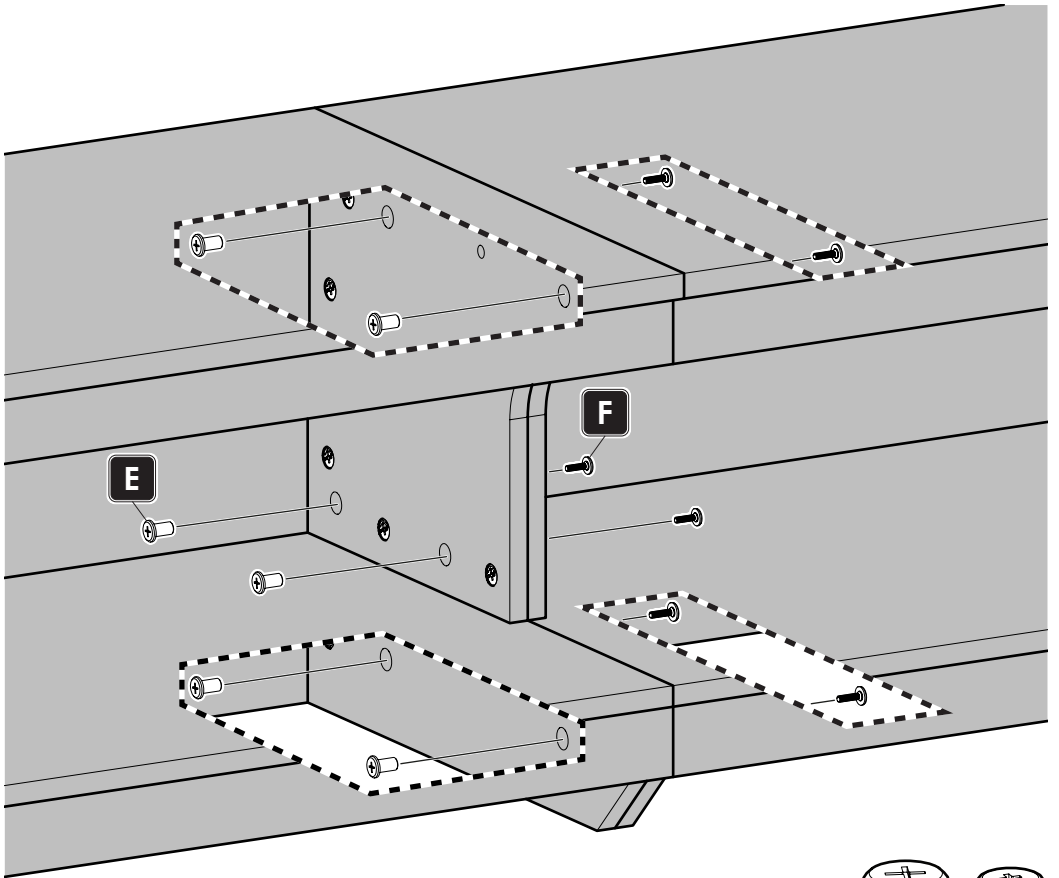
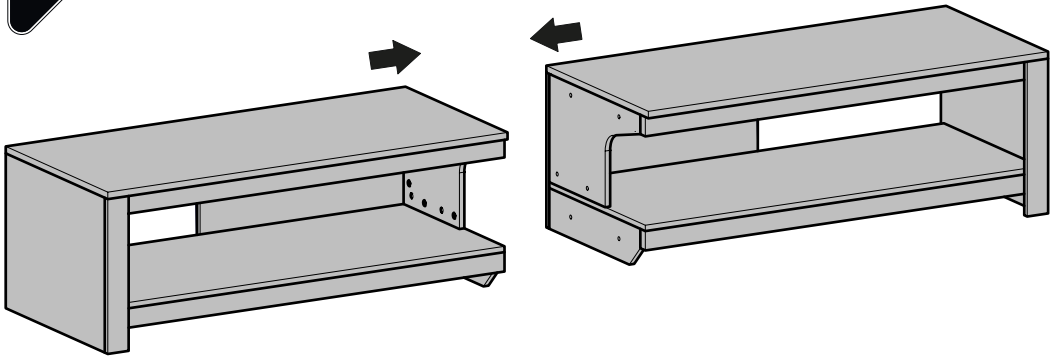

E
X6

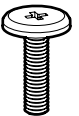

F
X6

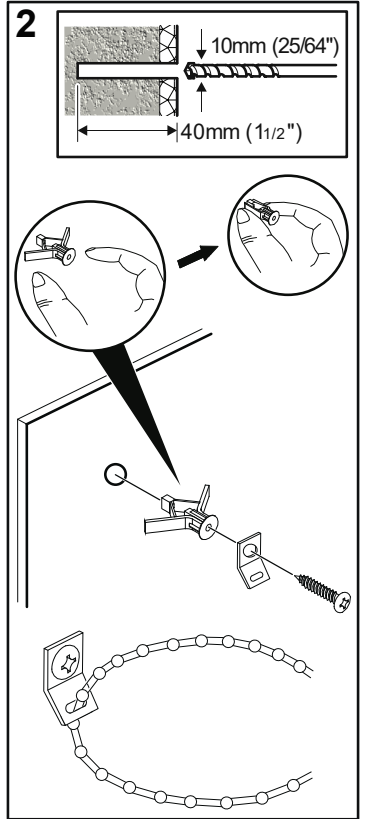
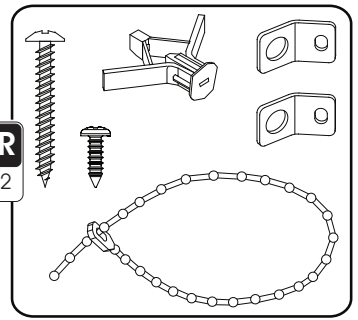
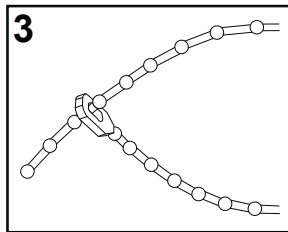
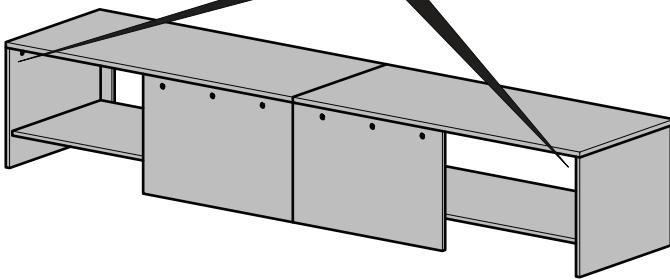
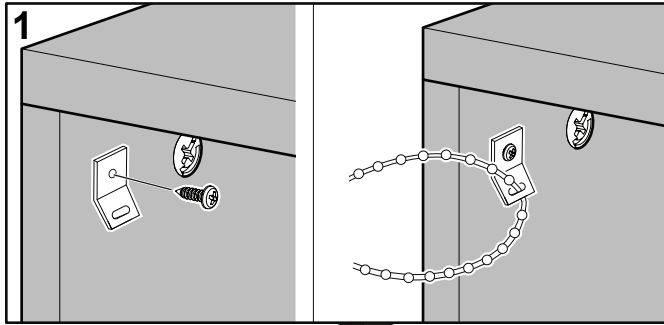

1. Attach the brackets to the back of the stand using the shorter screws. Position your stand against the wall and mark drill points on the wall in line with the brackets.

2. Drill the wall. Pinch the wings of the wall anchor together and push fully in to the wall. Attach the remaining brackets to the wall with the longer screws.

3. Insert a restraint strap through one set of brackets then pull it through the keyhole until it is tight. Pull the end of the strap down until it locks into place in the keyhole slot. Pull the end of the strap back through the keyhole strap to double lock the restraint.