

Care Instructions:

This product uses wood effect veneer, slight colour change over time due to exposure to natural light is to be expected.

Avoid direct sunlight as this can produce colour changes in the areas affected.

Colour and pattern variation is to be expected with this natural material and does not constitute a product defect.

Clean all surfaces using a soft damp cloth. A suitable furniture polish can be used if required.

Do not use abrasive cleaners.

Do not place hot or cold items in direct contact with any part of this product.

Take care not to overtighten any part of this assembly.

CUSTOMER SERVICES HELP LINE NUMBER: +44 (0) 333 320 0463 (UK)
1-800 667 0808 (USA)

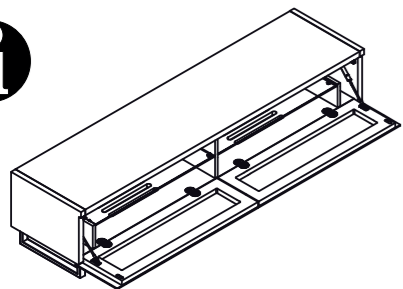

PANORAMA PM160



Take care not to overload the stand.
MAX 50Kg top, 20Kg shelf, 30Kg lower



Build the stand on a soft surface to prevent risk of scratching.



Take extra care not to over tighten any screws as this may cause damage!

Tools



[N] x 1



[O] x 1

Main Parts

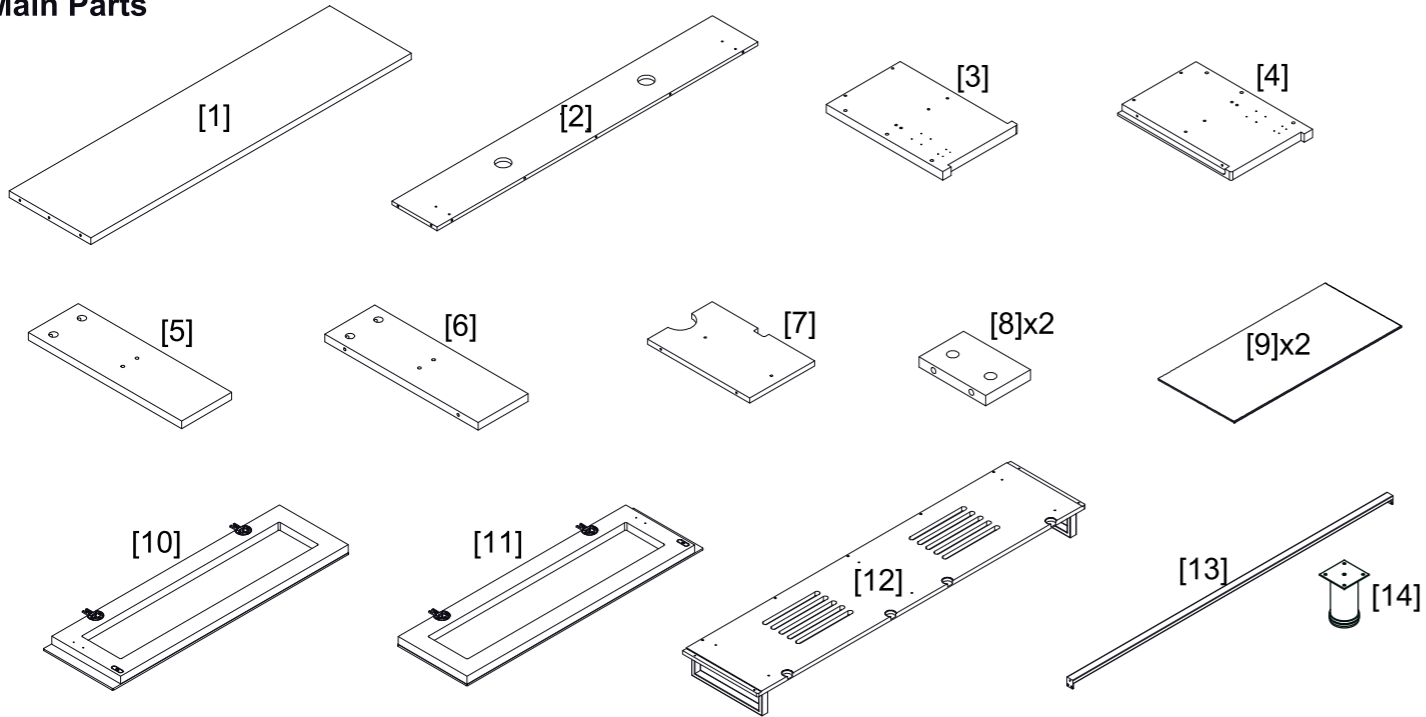

Components

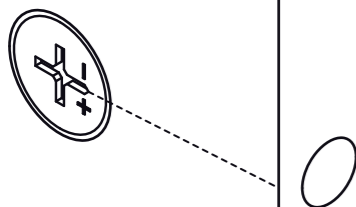
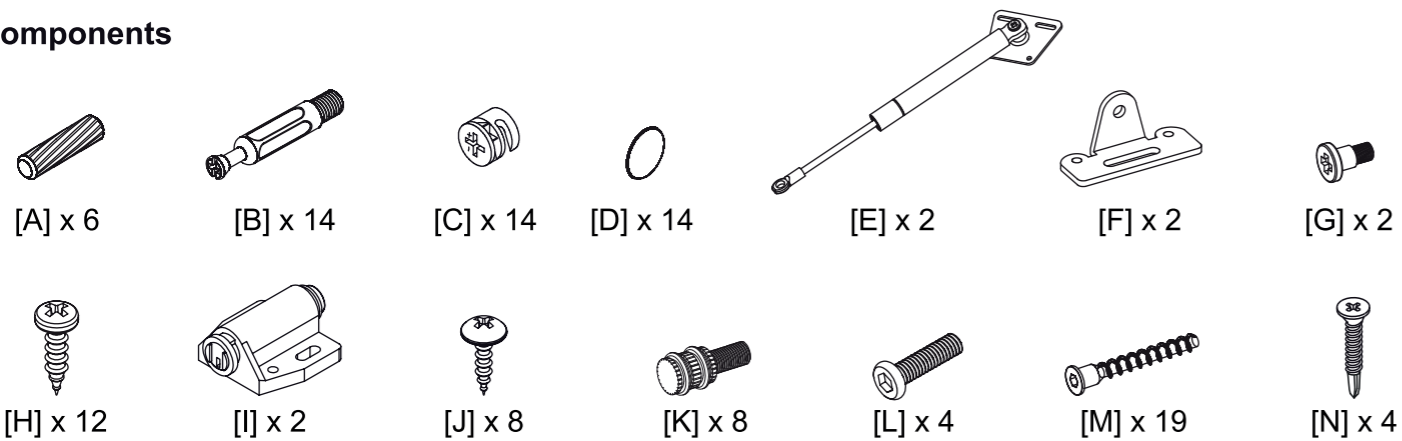

Make sure the arrows on all part C are aiming towards the panel edge when inserted.

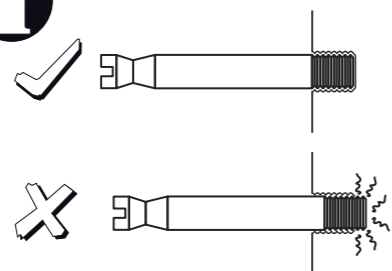

Make sure not to over tighten any part B as this could cause damage or error in alignment of panels.



Some construction steps may be easier with proper tools.

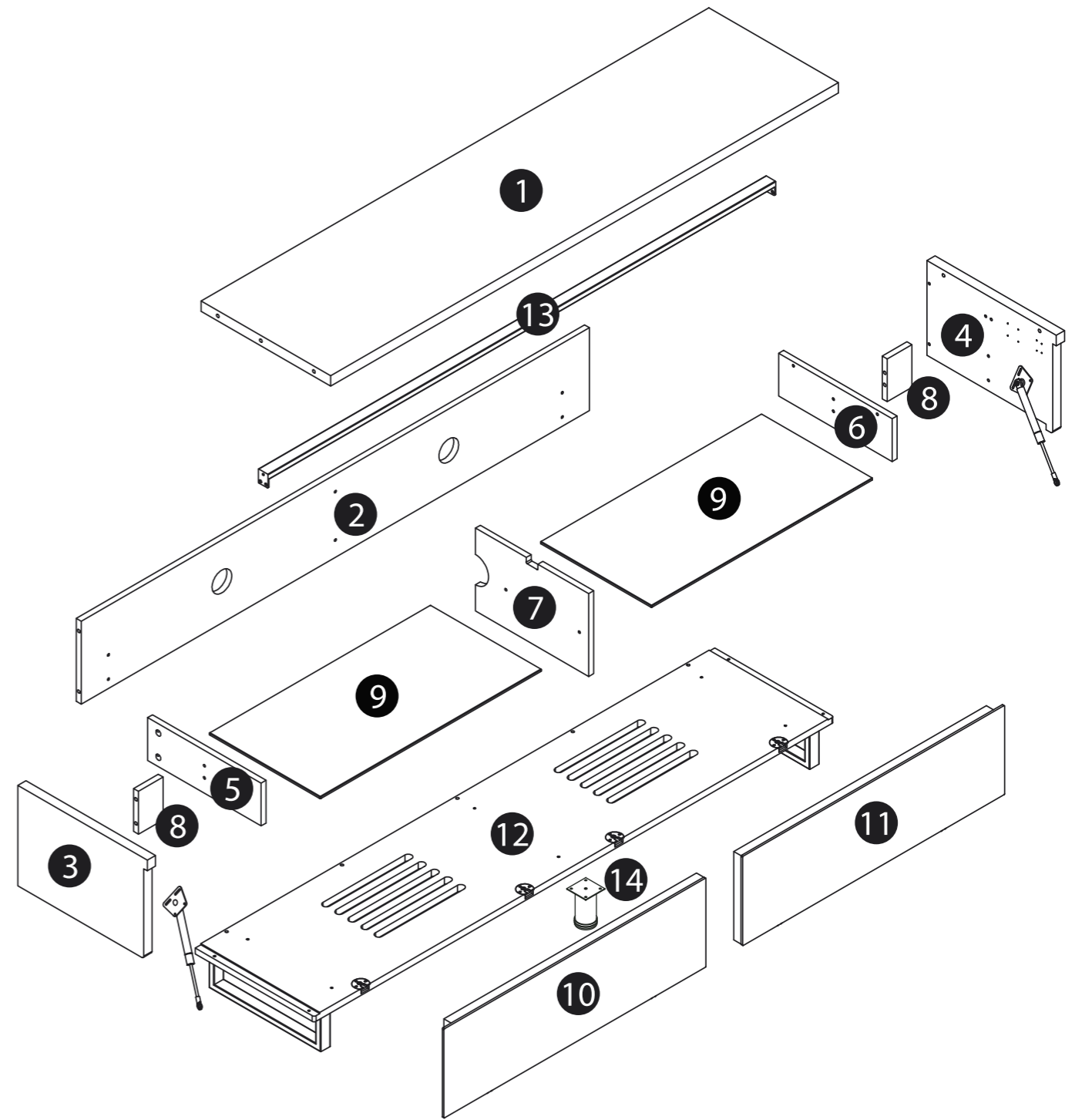

1

(B) x6

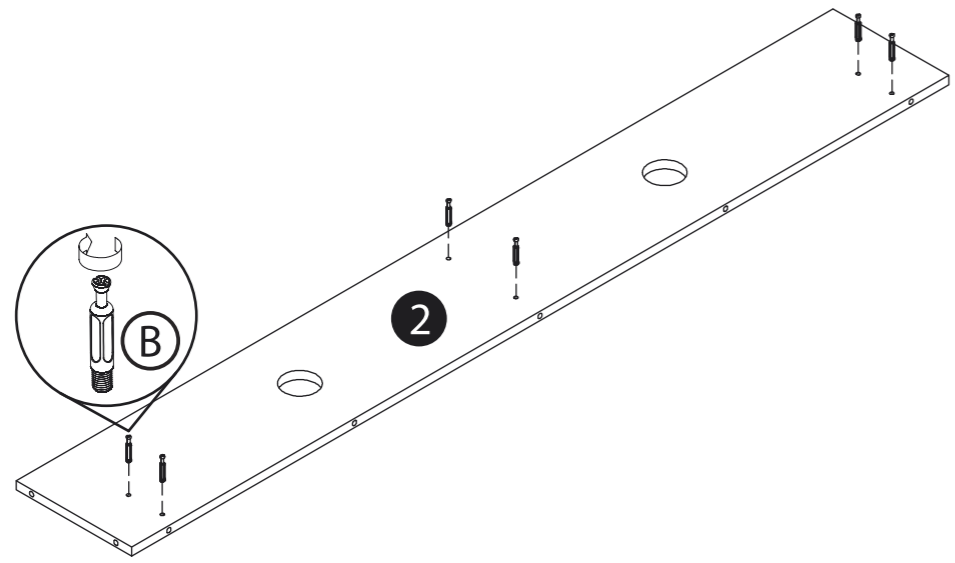

2

NOTE: Use the stickers (D) to cover the components (C) once tightened and secure.

(C) x6

(D) x6

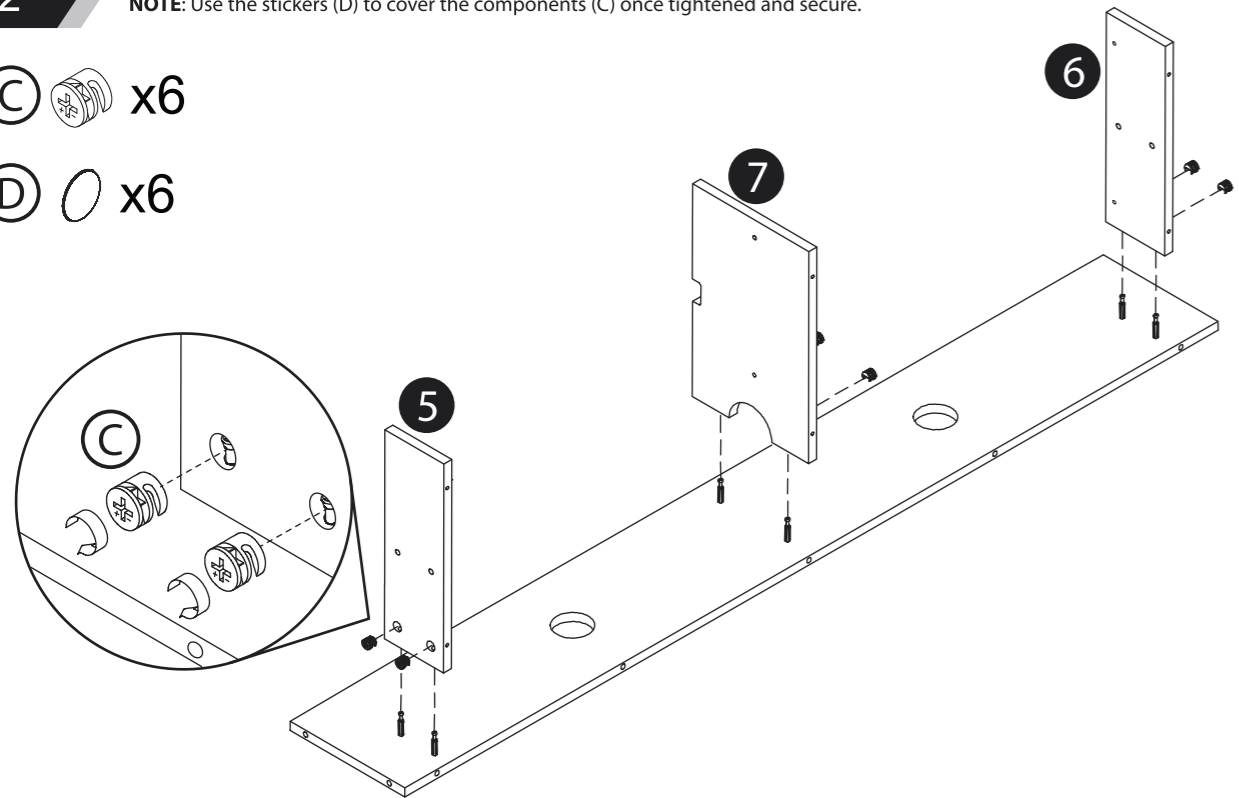

3

(K) x8

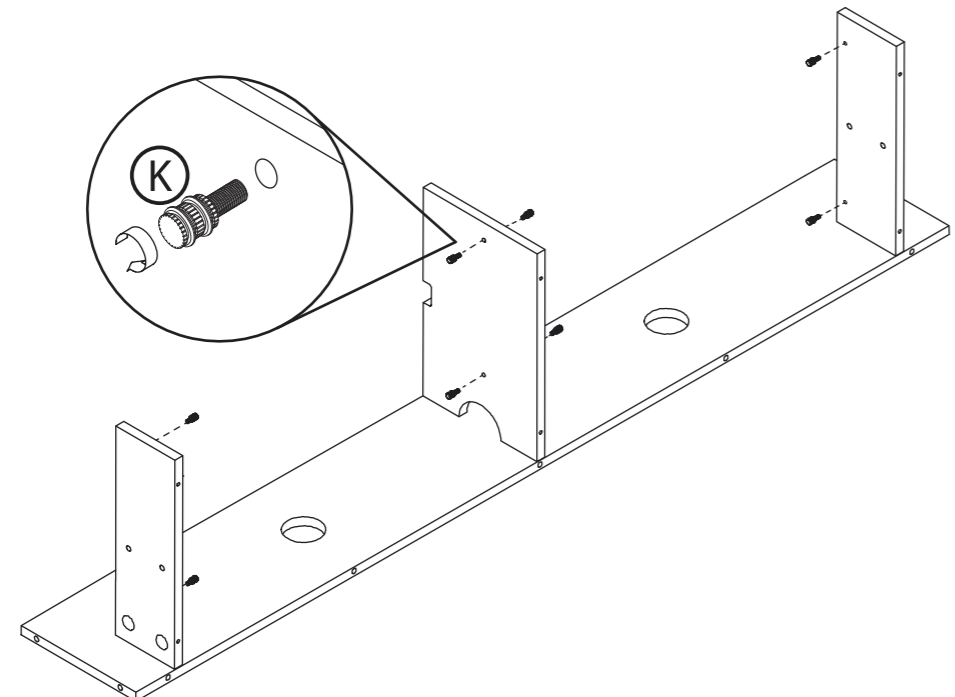

15

NOTE: Remove protective film from the side panels to show the high gloss finish.

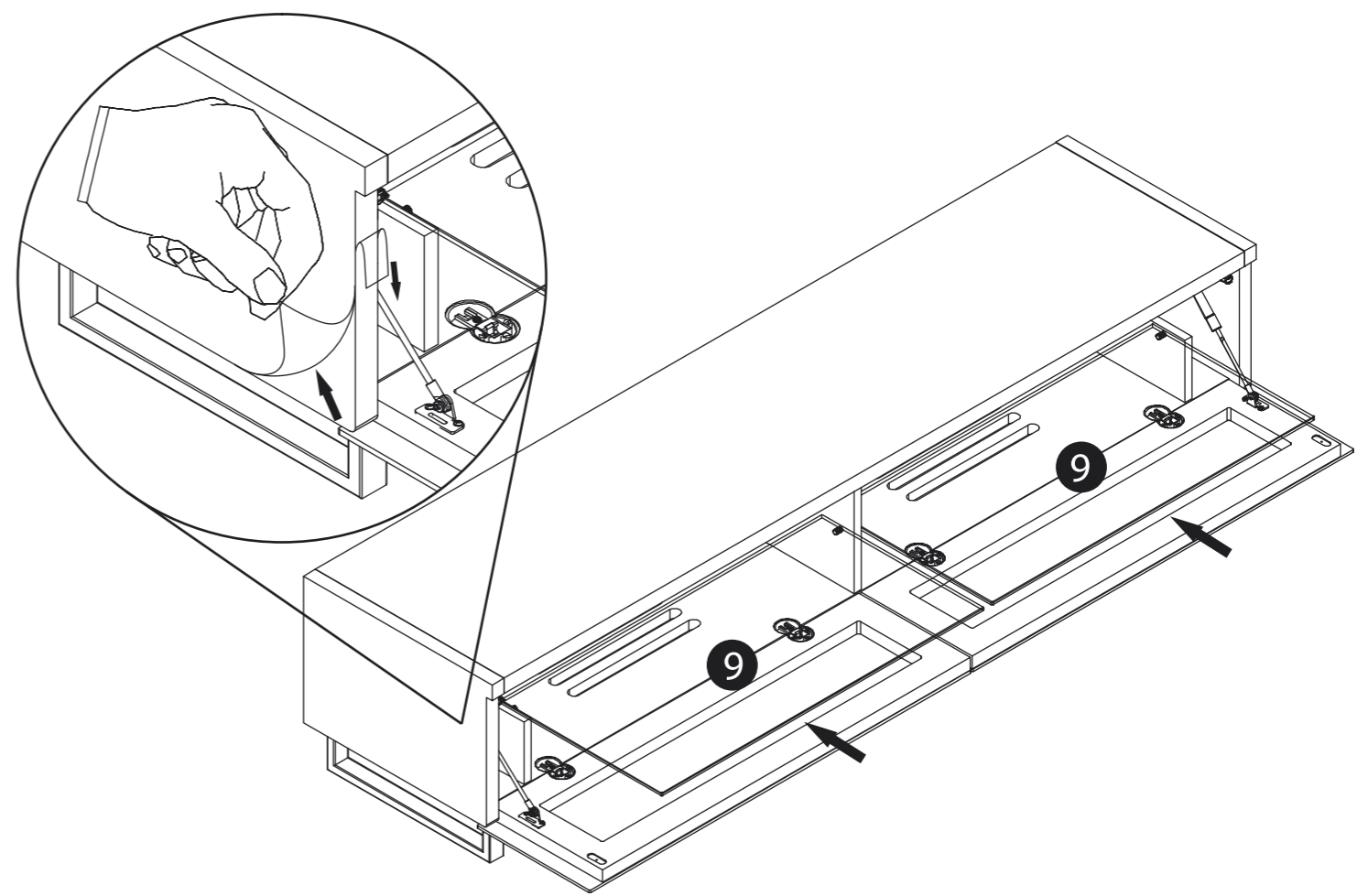

16

NOTE: If the doors dont close properly or dont align fully adjust the hinge screw slightly as shown to fix alignment.

(P) x4

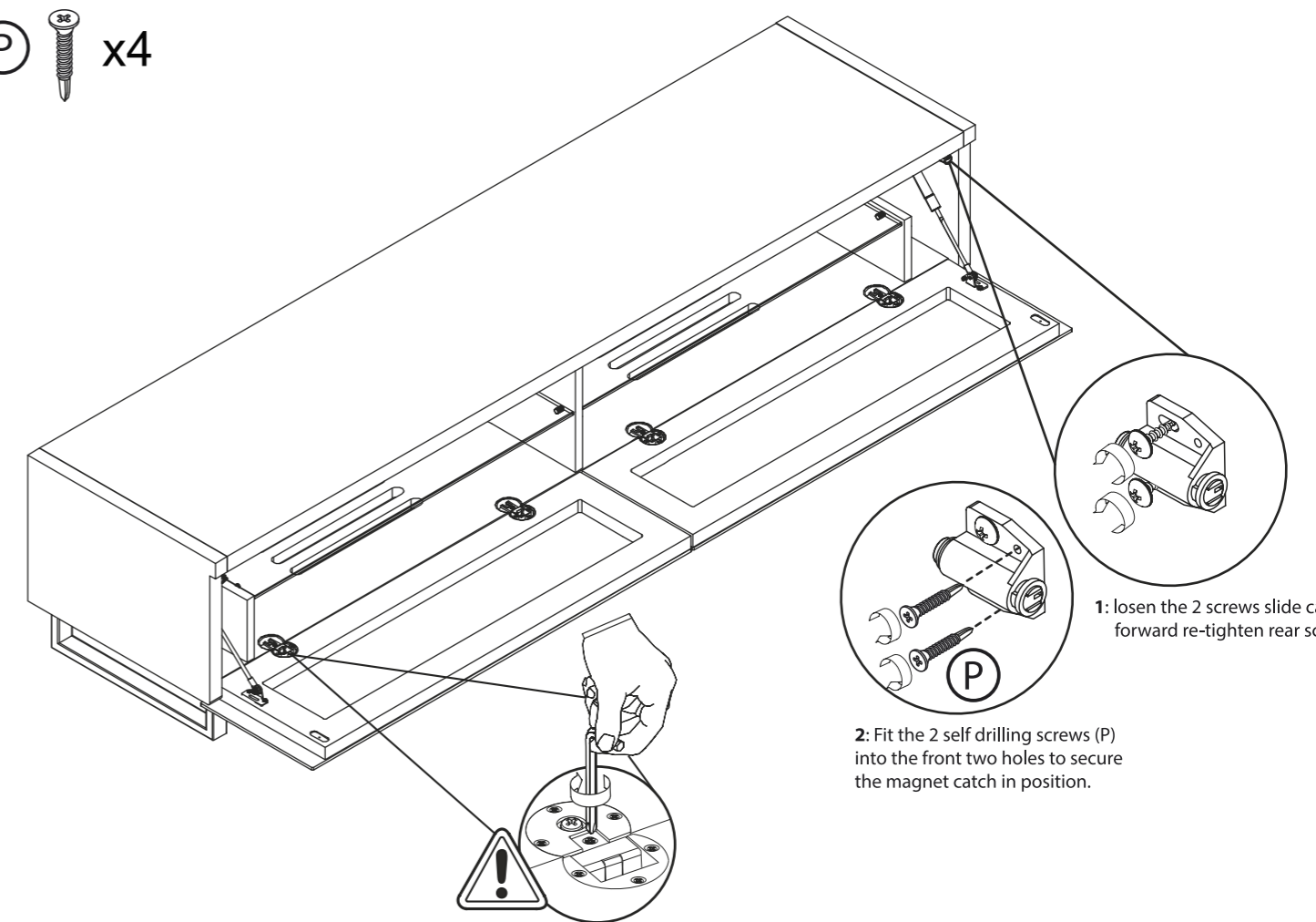

1: loosen the 2 screws slide catch forward re-tighten rear screws.

2: Fit the 2 self drilling screws (P) into the front two holes to secure the magnet catch in position.

12

(C)  x4

(D)  x4

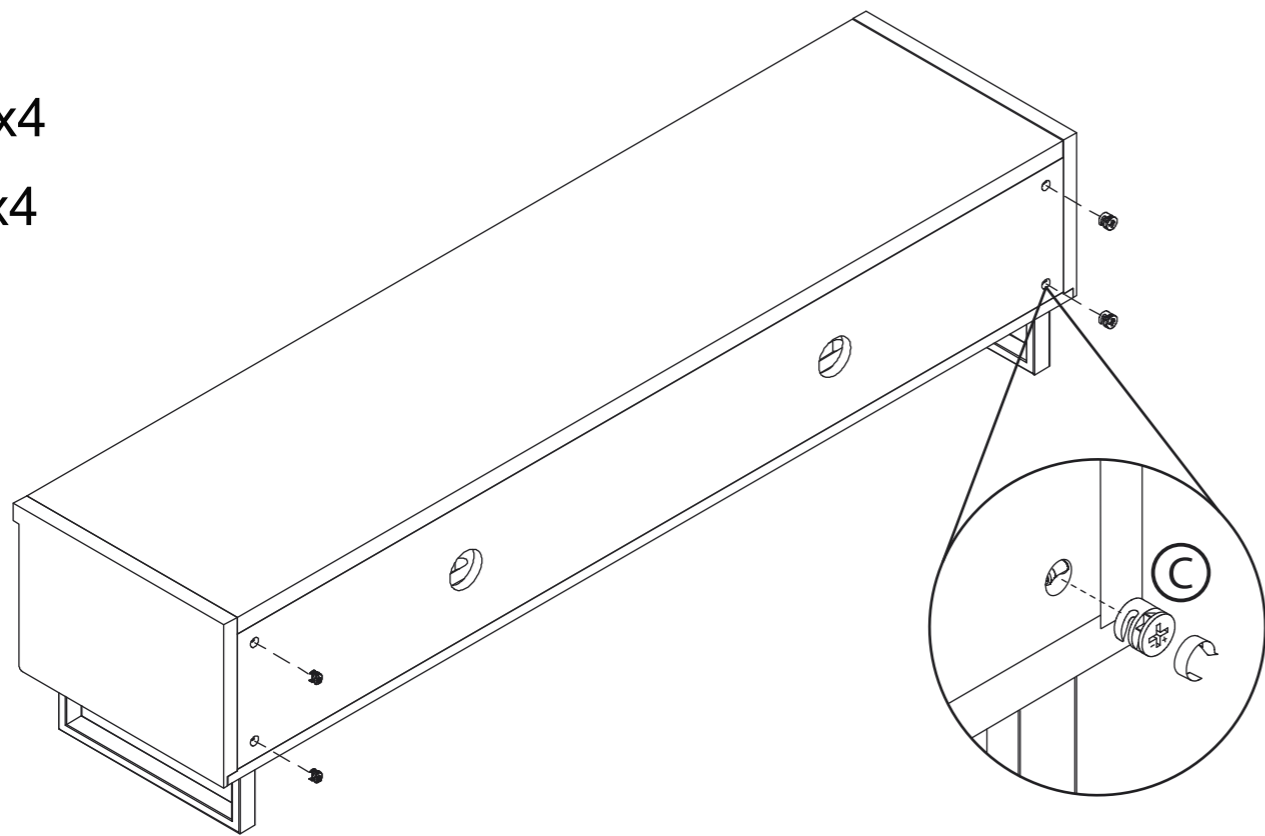

13

(F)  x2

(H)  x4

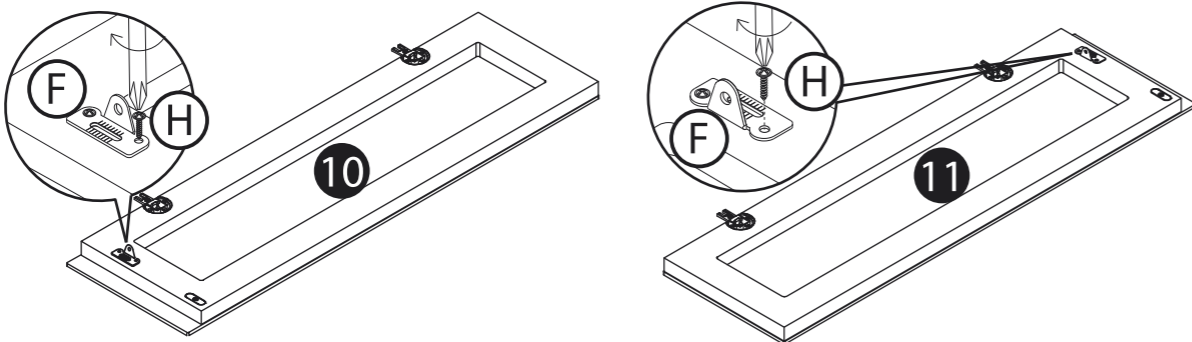

14

NOTE: When fitting the doors loosen the pre-installed hinge screw on the main unit and slide the door into position, once in tighten the screw to secure the door in place.

(G)  x2

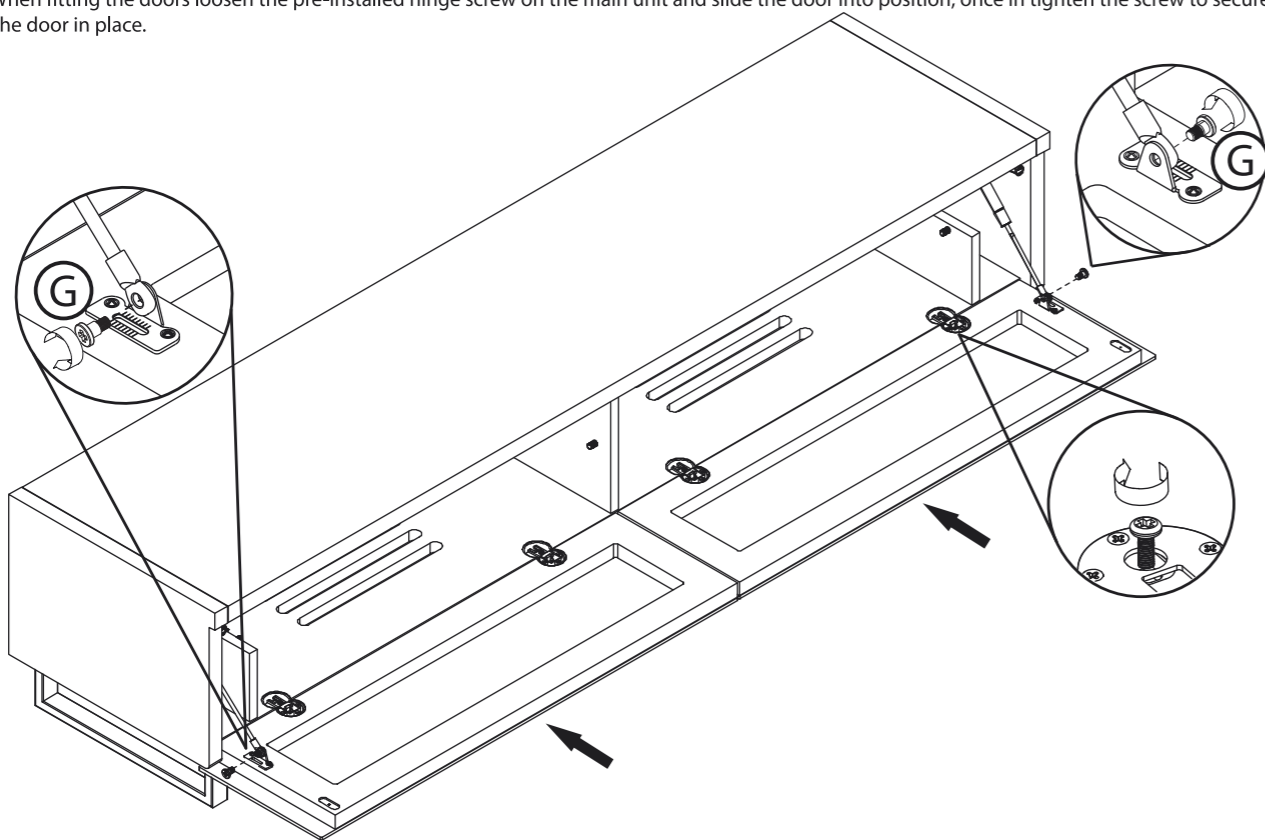

4

(B)  x8

(J)  x4

(I)  x2

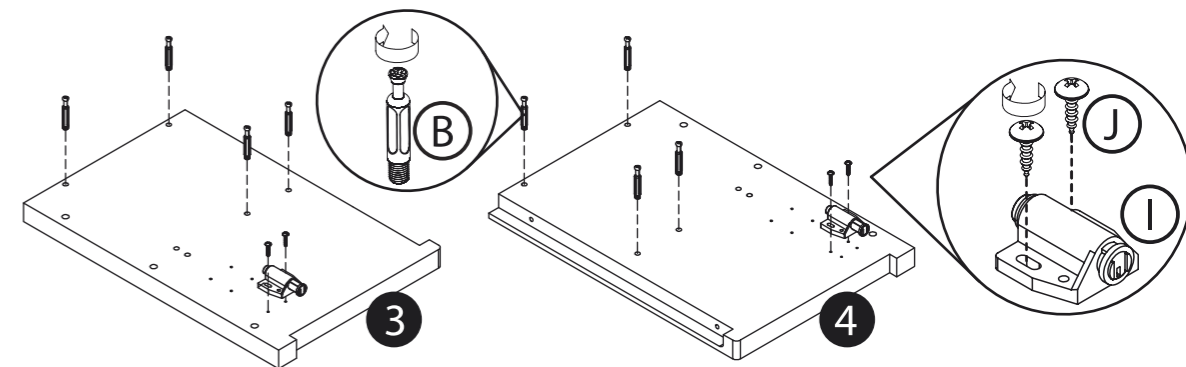

5

(H)  x8

(E)  x2

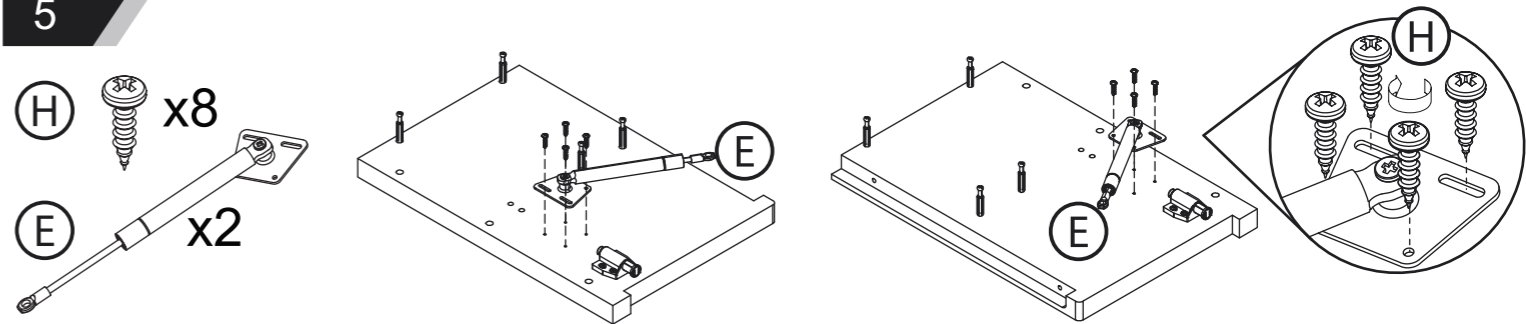

6

(C)  x4

(D)  x4

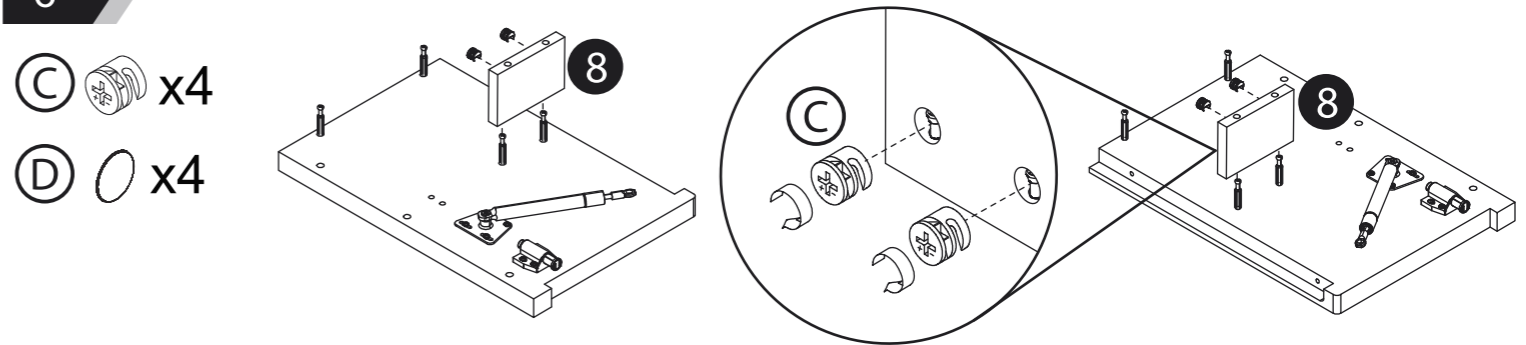

7

(M)  x2

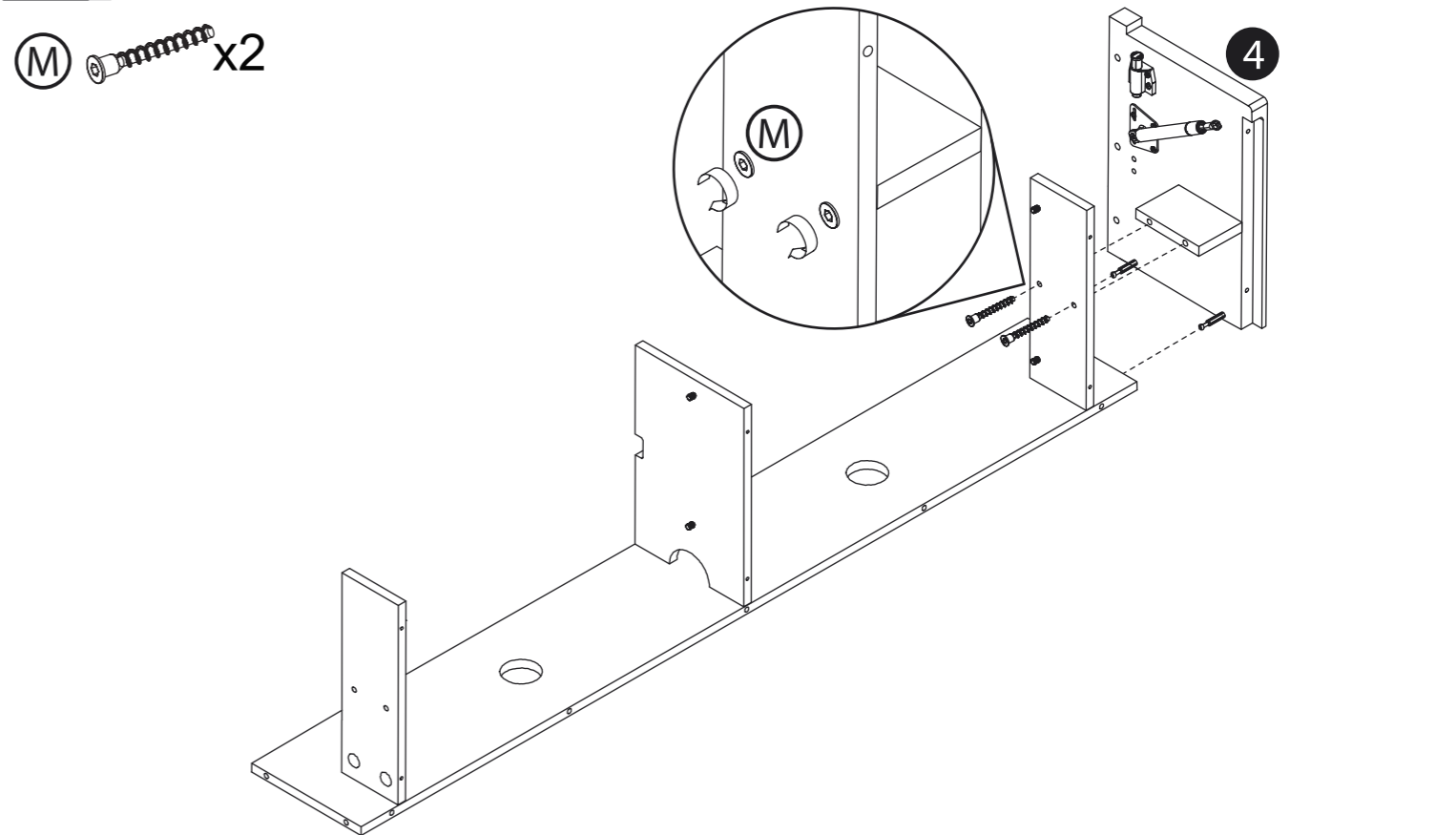

8

(L) x2

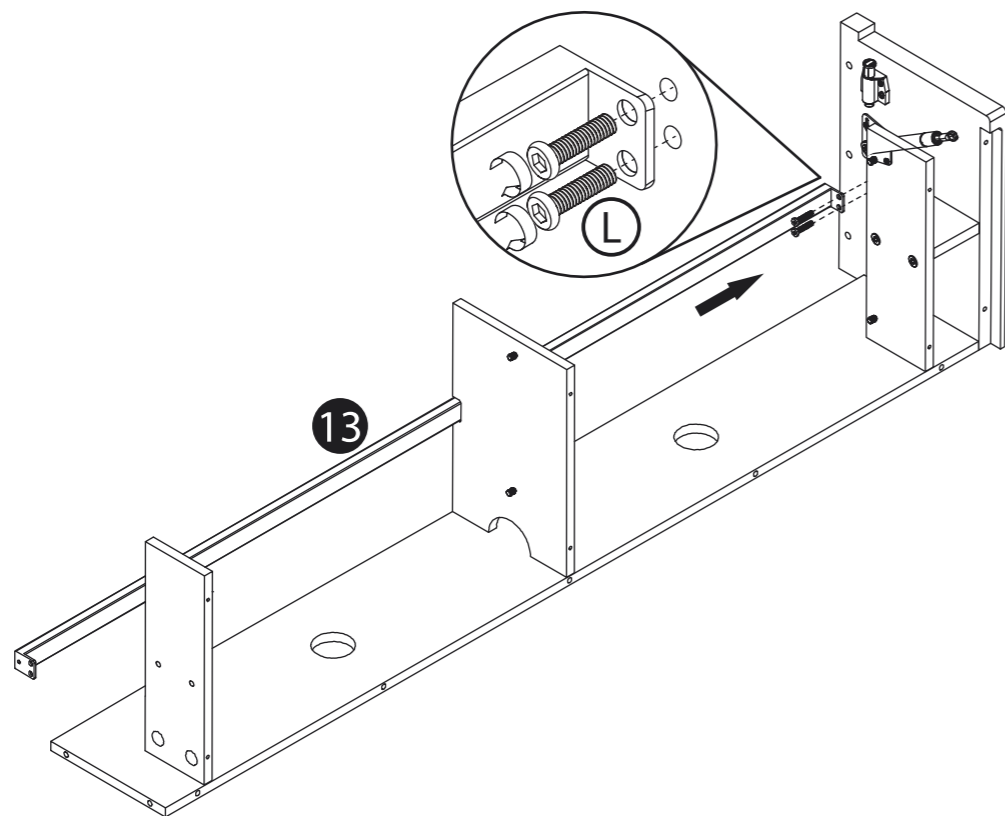

10

(M) x2

(L) x2

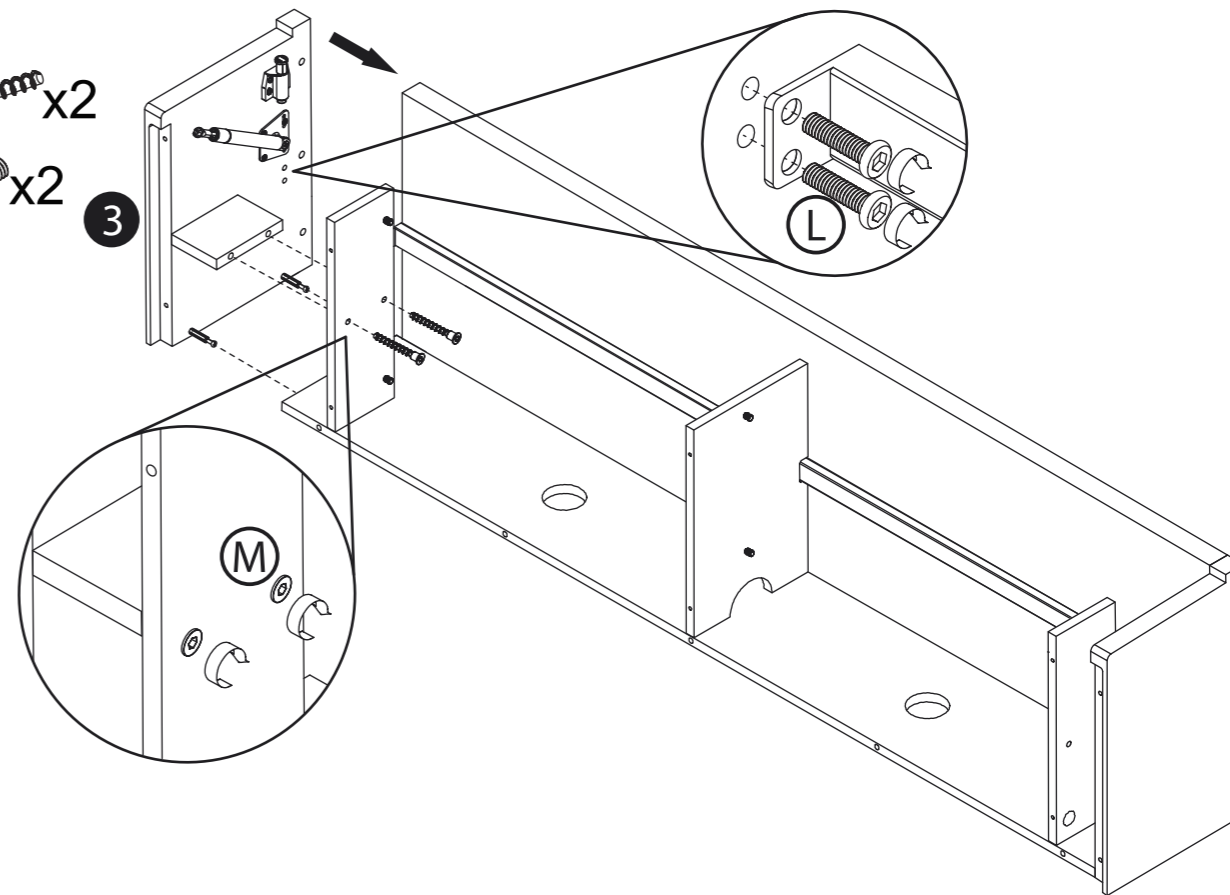

9

NOTE: Make sure part 9 is the correct way round so the top and front finishes match.

(A) x6

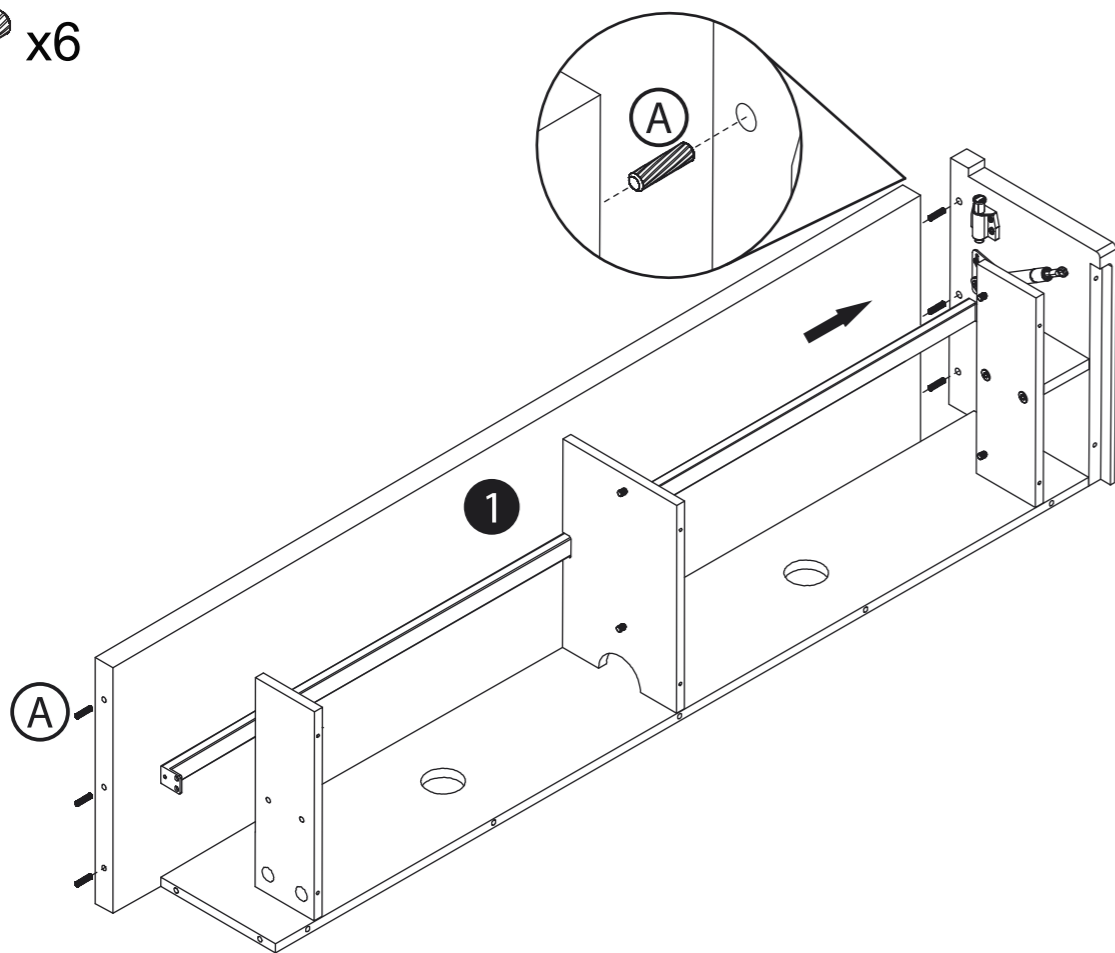

11

NOTE: Once fitted part 14 should be adjusted to match the height of the two legs.

(M) x15

(J) x4

